

"PV2R" Series Single Vane Pumps

These pumps are of high pressure and high performance, which have been developed especially for low noise operation. To comply with a variety of applications including injection moulding machines, PV2R series single pumps provide the output flow of such a wide range as from 5.8 to 237 cm³/rev (.354 to 14.46 cu.in./rev).

The intergral driving parts of the pumps are combined into a kit form and available for supply as a cartridge kit. Therefore, the replacement of the driving parts can be done easily.

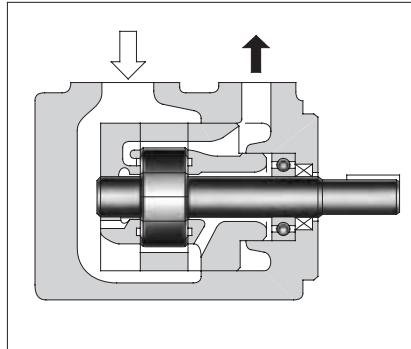

Graphic Symbol

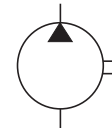

B



"PV2R" Series
Single Vane Pumps

Model Number Designation

F-	PV2R1	-6	-L	-R	A	A	-42	-*
Special Seals	Series Number	Nominal Displacement cm ³ /rev	Type of Mounting	Shaft Rotation	Discharge Port Position	Suction Port Position	Design Number	Design Standards
F: For phosphate ester type fluids (Omit if not required)	PV2R1	6, 8, 10, 12, 14, 17, 19, 23, 25, 31	L: Foot Mounting	R: Clockwise* ¹ (Normal)	A: Upwards (Normal)	A: Upwards (Normal)	42	Refer to ★ ²
	PV2R2	41, 47, 53, 59, 65					41	
	PV2R3	76, 94, 116	F: Flange Mounting				31	
	PV2R4	136, 153, 184, 200, 237	30					

★¹. Available to supply pump with anti-clockwise rotation. Consult Yuken for details.

★². Design Standards: None.....Japanese Standard "JIS"
80.....European Design Standard
90.....N. American Design Standard

Pipe Flange Kits

Pipe flange kits are available. When ordering, specify the kit number from the table below.

Pump Model Numbers	Name of Port	Pipe Flange Kit Numbers						
		Threaded Connection			Socket Welding* ¹		Butt Welding	
		Japanese Standard "JIS"	European Design Standard	N. American Design Standard* ²	Japanese Standard "JIS" European Design Standard	N. American Design Standard* ²	Japanese Standard "JIS" European Design Standard	N. American Design Standard* ²
PV2R1	Suction	F5-08-A-10	F5-08-A-1080	—	F5-08-B-10	F5-08-B-1090	F5-08-C-10	F5-08-C-1090
	Discharge	F5-04-A-10	F5-04-A-1080	—	F5-04-B-10	F5-04-B-1090	F5-04-C-10	F5-04-C-1090
PV2R2	Suction	F5-10-A-10	F5-10-A-1080	—	F5-10-B-10	F5-10-B-1090	F5-10-C-10	F5-10-C-1090
	Discharge	F5-06-A-10	F5-06-A-1080	—	F5-06-B-10	F5-06-B-1090	F5-06-C-10	F5-06-C-1090
PV2R3	Suction	F5-16-A-10	F5-16-A-1080	—	F5-16-B-10	F5-16-B-1090	F5-16-C-10	F5-16-C-1090
	Discharge	F5-10-A-10	F5-10-A-1080	—	F5-10-B-10	F5-10-B-1090	F5-10-C-10	F5-10-C-1090
PV2R4	Suction	F5-24-A-10	—	—	F5-24-B-10	F5-24-B-1090	F5-24-C-10	F5-24-C-1090
	Discharge	F5-12-A-10	F5-12-A-1080	—	F5-12-B-10	F5-12-B-1090	F5-12-C-10	F5-12-C-1090

★¹. In case of using socket welding flanges, there is a case where the operating pressure should be set lower than the normal because of strength of the flanges. Therefore, please pay cautious attention to the operating pressure when the socket welding flanges are used.

★². As dimensions of the pipe flange mounting surface are conformed to SAE 4 Bolt Split Flange (Standard Pressure Series), pipe flanges conforming to the SAE Standards can be used.

Notes: Special seals (Viton seals) are required when phosphate ester type fluids are used. (Prefix "F-" to the pipe flange kit number when ordering.)

● Details of the pipe flange kits are shown on page 824.

Specifications

Model Numbers	Geometric Displacement cm ³ /rev (cu.in./rev)	Max. Operating Pressure MPa (PSI)						Output Flow & Input Power	Shaft Speed Range r/min	
		Petroleum Base Oils		Water Containing Fluids			Synthetic Fluids		Max.	Min.
		Anti-Wear Type	R & O Type	Anti-Wear Type Water Glycols ^{★1}	Water Glycols	Water in Oil Emulsions	Phosphate Esters			
PV2R1-6	5.8 (.354)	21 ^{★6} (3050)	16 (2320)	16 (2320)	7 (1020)	7 (1020)	16 (2320)	Refer to Pages 170 - 172	1800 (1200) ^{★4}	750 ^{★5}
PV2R1-8	8.0 (.488)									
PV2R1-10	9.4 (.574)									
PV2R1-12	12.2 (.744)									
PV2R1-14	13.7 (.836)									
PV2R1-17	16.6 (1.013)									
PV2R1-19	18.6 (1.135)									
PV2R1-23	22.7 (1.385)									
PV2R1-25	25.3 (1.544)	16 (2320)						Refer to Pages 172 & 173	1800 (1200) ^{★4}	600 ^{★5}
PV2R1-31	31.0 (1.892)									
PV2R2-41	41.3 (2.52)	21 (3050)	14 (2030)	16 (2320)	7 (1020)	7 (1020)	14 (2030)	Refer to Pages 172 & 173	1800 (1200) ^{★4}	600 ^{★5}
PV2R2-47	47.2 (2.88)									
PV2R2-53	52.5 (3.20)									
PV2R2-59	58.2 (3.55)									
PV2R2-65	64.7 (3.95)									
PV2R3-76	76.4 (4.66)	21 (3050)	14 (2030)	16 (2320)	7 (1020)	7 (1020)	14 (2030)	Refer to Page 174	1800 (1200) ^{★4}	600
PV2R3-94	93.6 (5.71)									
PV2R3-116	115.6 (7.05)	16 (2320)							1800 ^{★2} (1200) ^{★4}	
PV2R4-136	136 (8.30)	17.5 (2540)	14 (2030)	16 (2320)	7 (1020)	7 (1020)	14 (2030)	Refer to Pages 174 & 175	1800 (1200) ^{★4}	600
PV2R4-153	153 (9.34)									
PV2R4-184	184 (11.23)									
PV2R4-200	201 (12.27)									
PV2R4-237	237 (14.46)									

- ★1. For the brands of anti-wear type water-glycols , see the item of "Hydraulic Fluids" on page 160.
- ★2. If PV2R3-116 is used at speed above 1700 r/min, the suction pressure is limited to 0 kPa (0 in. Hg.).
- ★3. If PV2R4-237 is used at speed above 1700 r/min, the suction pressure is limited to -13 kPa (3.94 in. Hg. vacuum).
- ★4. If phosphate ester or water containing fluids are used, the maximum speed is limited to 1200 r/min.
- ★5. For starting at low speed, the maximum viscosity is limited. For details, see the item of "Hydraulic Fluids" on page 160.
- ★6. For pressure above 16 MPa (2320 PSI), raise the speed over 1450 r/min.

● Mass

Model Numbers	Approx. Mass kg (lbs.)	
	Flange Mtg.	Foot Mtg.
PVR2R1	9.0 (19.8)	11.2 (24.7)
PVR2R2	15.5 (34.2)	19.8 (43.7)
PVR2R3	30.9 (68.1)	40.9 (90.2)
PVR2R4	68.5 (151)	93.5 (206)



Flange Mtg.: PV2R1-*-F-RAA-42/4290

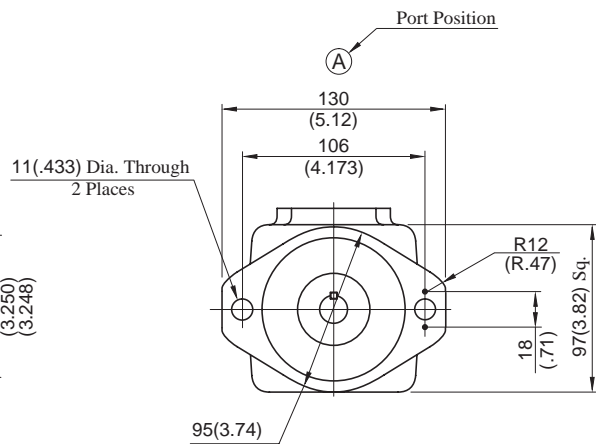
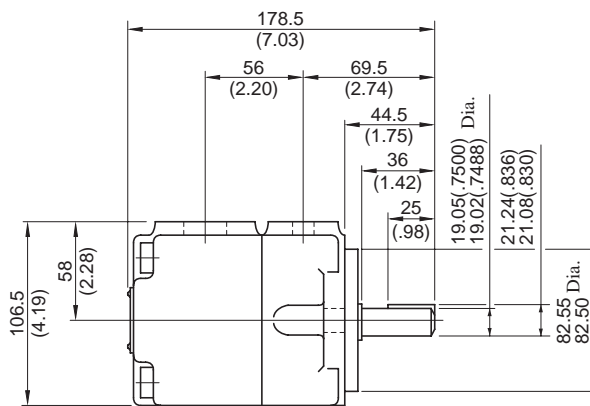
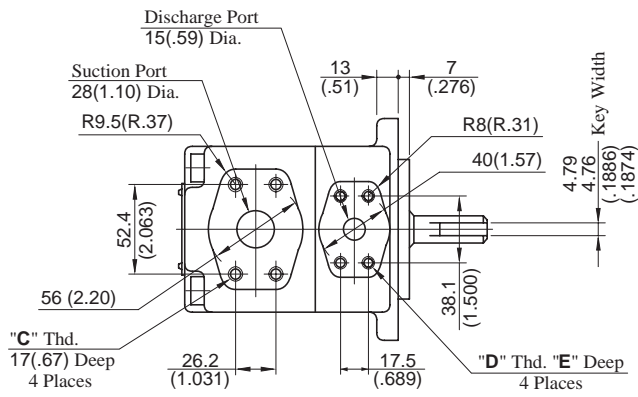

Model Numbers	"C" Thd.	"D" Thd.	E mm (Inches)
PV2R1-*-F-RAA-42	M10	M8	14 (.55)
PV2R1-*-F-RAA-4290	3/8-16 UNC	5/16-18 UNC	16 (.63)

DIMENSIONS IN MILLIMETRES (INCHES)

Foot Mtg.: PV2R1-*-L-RAA-42/4290

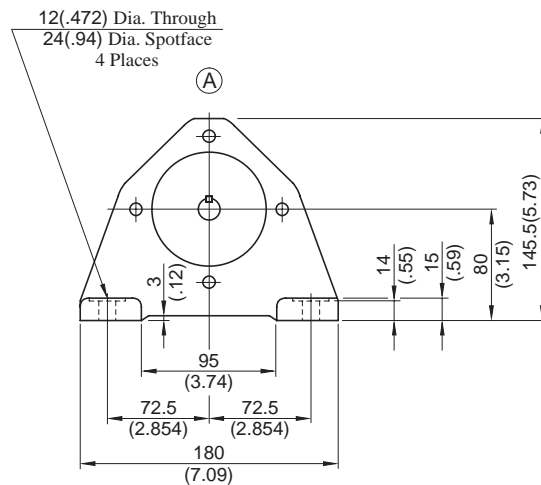
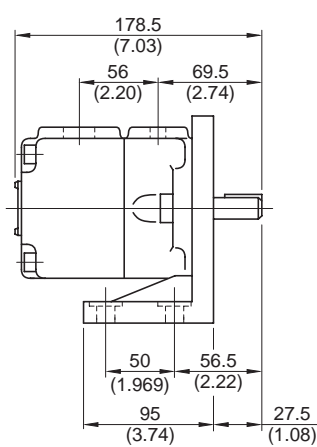

• For other dimensions, refer to "Flange Mtg.".

Flange Mtg.: PV2R2-*-F-RAA-41/4190

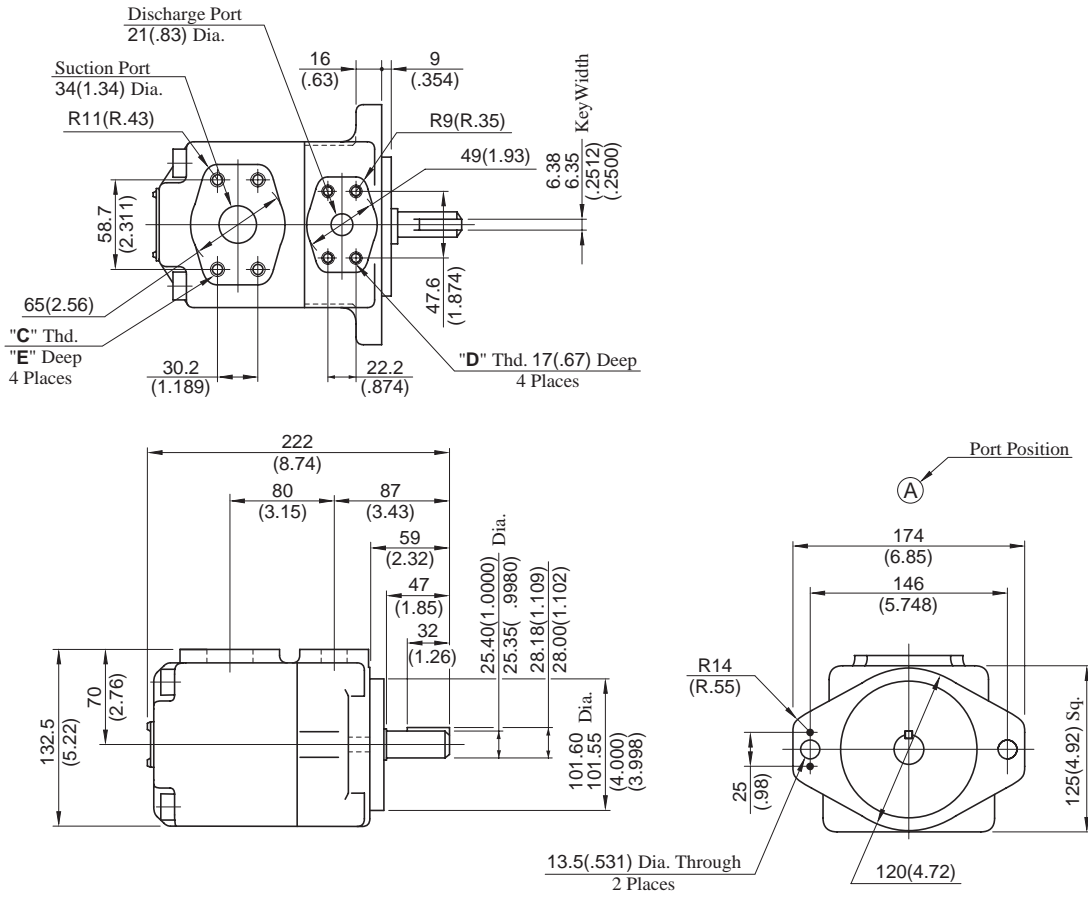

DIMENSIONS IN MILLIMETRES (INCHES)

Foot Mtg.: PV2R2-*-L-RAA-41/4190

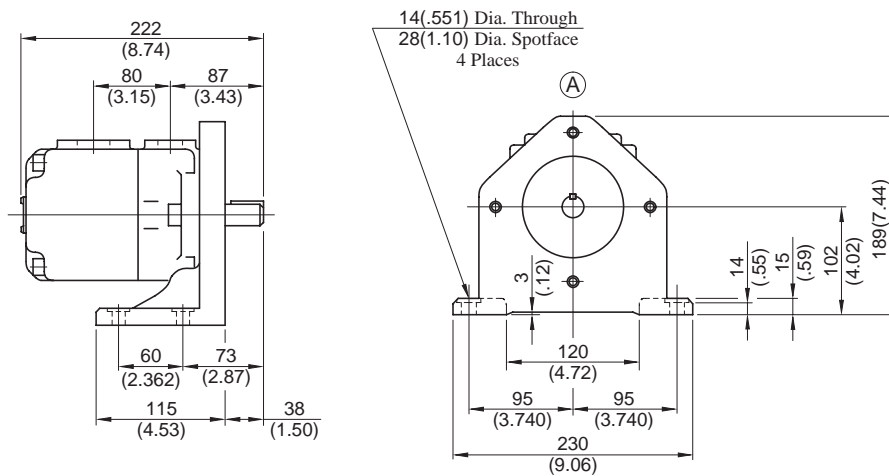

• For other dimensions, refer to "Flange Mtg.".



Flange Mtg.: PV2R3-*-F-RAA-31/3190

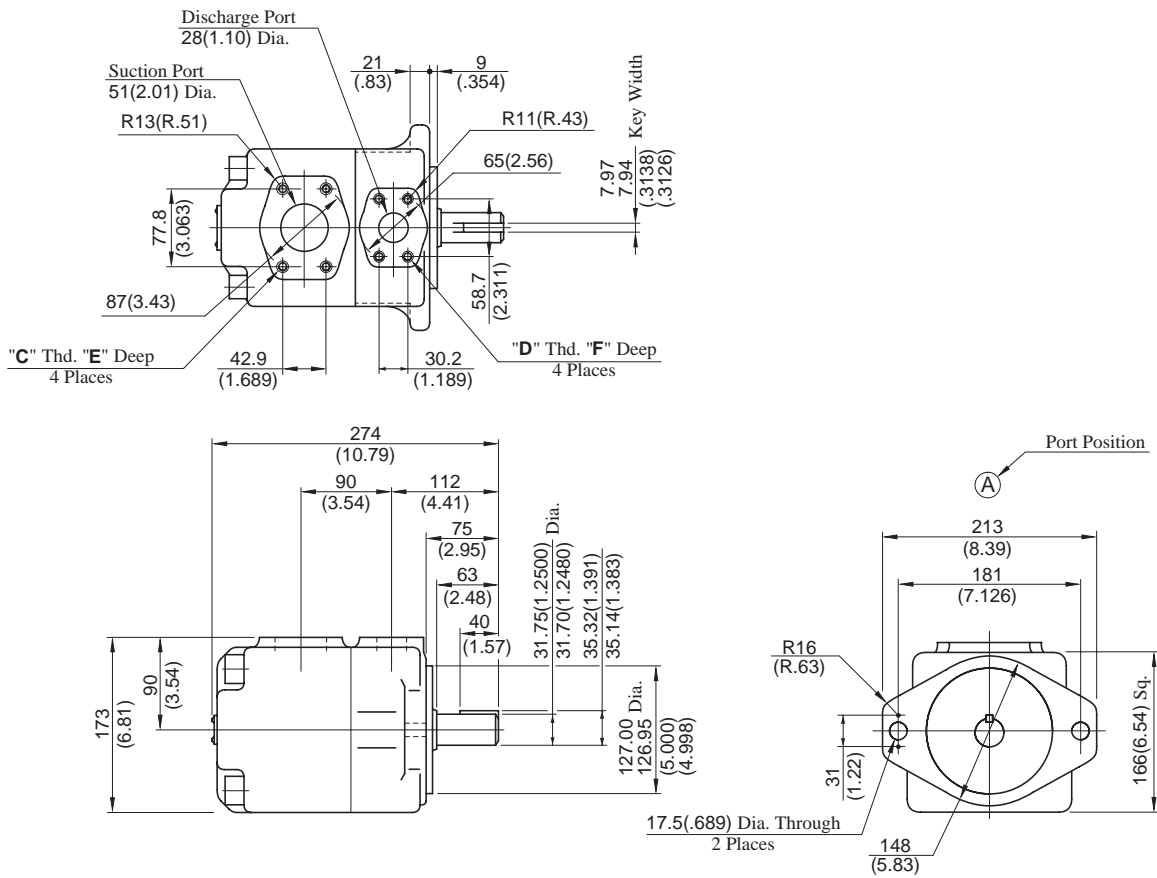

Model Numbers	"C" Thd.	"D" Thd.	Dimensions mm (Inches)	
			E	F
PV2R3-*-F-RAA-31	M12	M10	19 (.75)	19 (.75)
PV2R3-*-F-RAA-3190	1/2-13 UNC	7/16-14 UNC	21 (.83)	20 (.79)

DIMENSIONS IN
MILLIMETRES (INCHES)

Foot Mtg.: PV2R3-*-L-RAA-31/3190

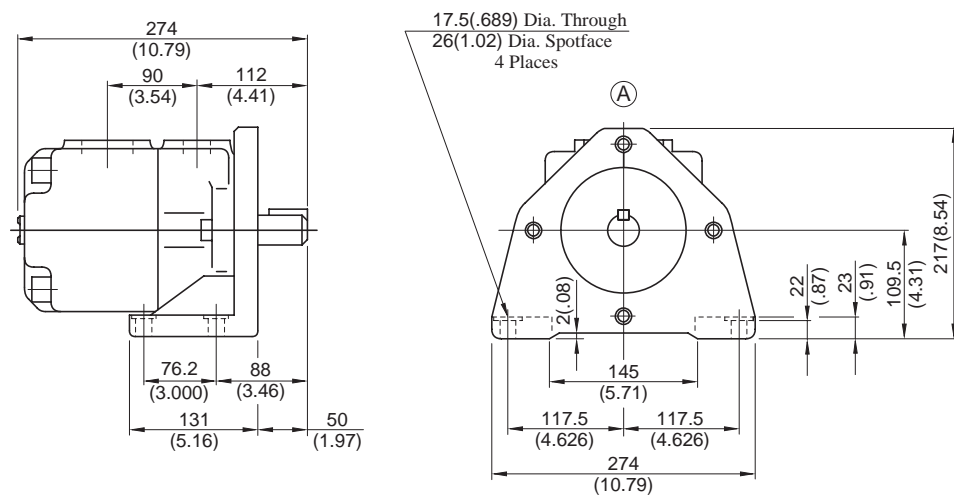

• For other dimensions, refer to "Flange Mtg.".

Flange Mtg.: PV2R4-*-F-RAA-30/3090

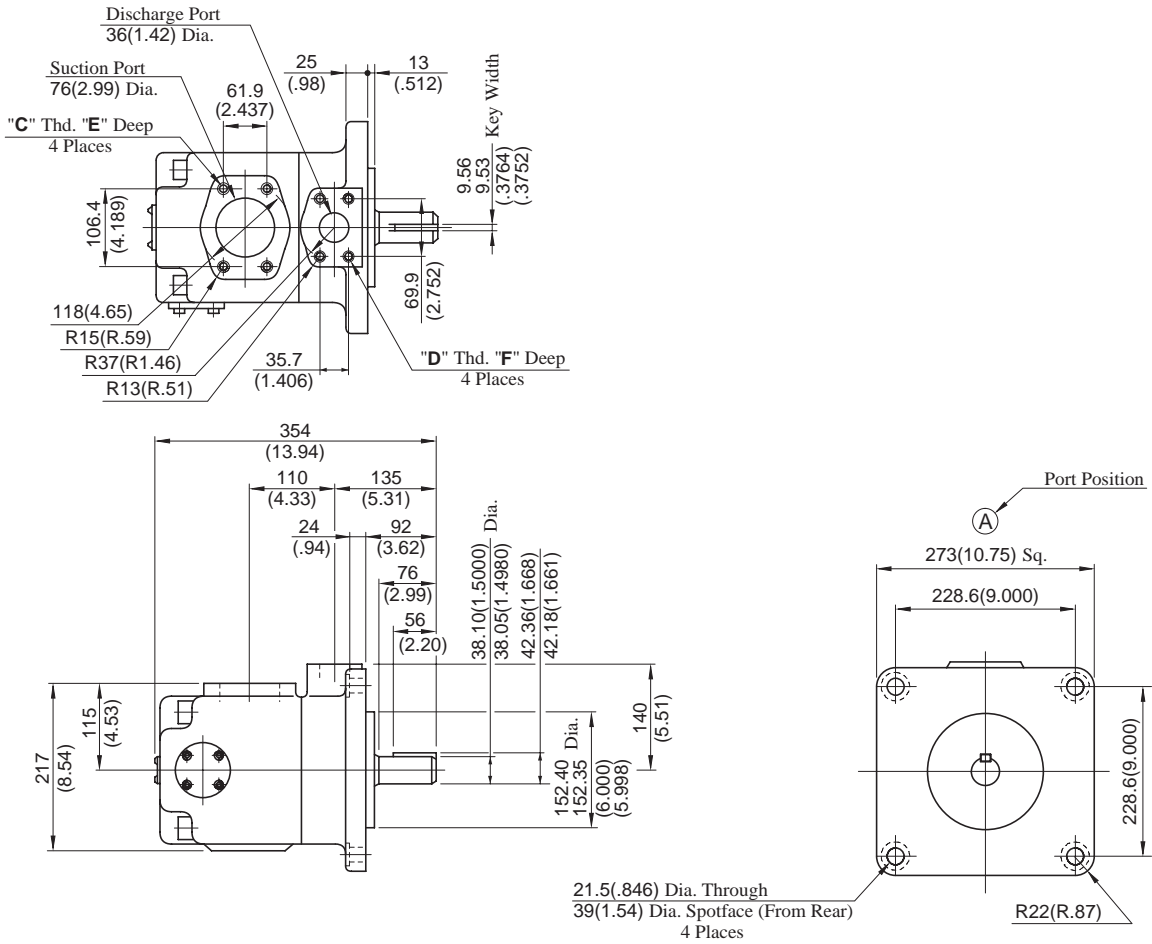

Model Numbers	"C" Thd.	"D" Thd.	Dimensions mm (Inches)	
			E	F
PV2R4-*-F-RAA-30	M16	M12	19 (.75)	19 (.75)
PV2R4-*-F-RAA-3090	5/8-11 UNC	1/2-13 UNC	21 (.83)	21 (.83)

DIMENSIONS IN MILLIMETRES (INCHES)

Foot Mtg.: PV2R4-*-L-RAA-30/3090

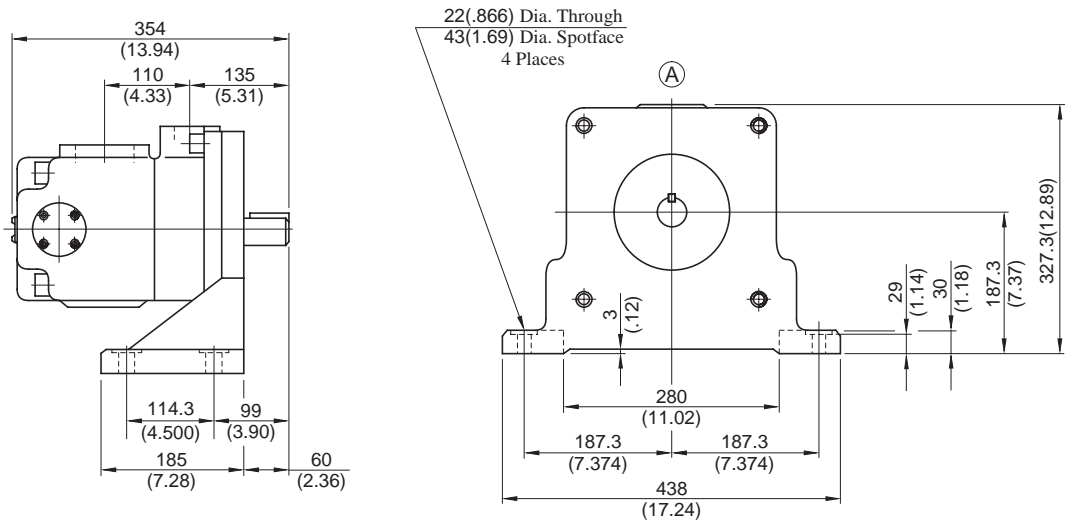

• For other dimensions, refer to "Flange Mtg.".



Noise Level

Measuring conditions

Fluid viscosity : 20 mm²/s (100 SSU)

Measurement point : One metre (3.3 ft.) horizontally away from pump head cover

Back ground noise : 40 dB (A)

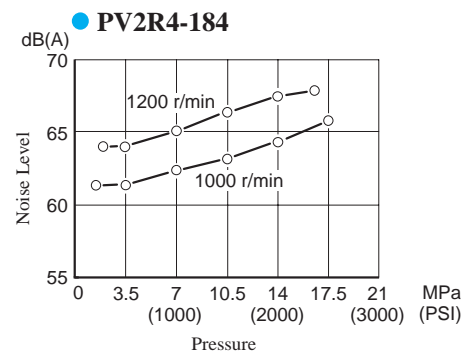
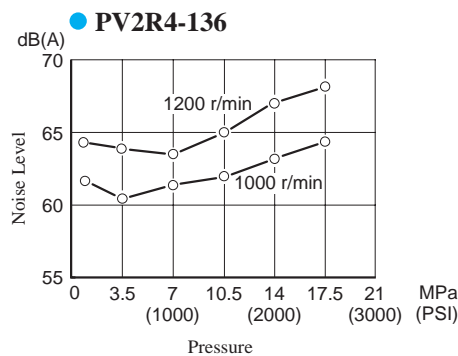
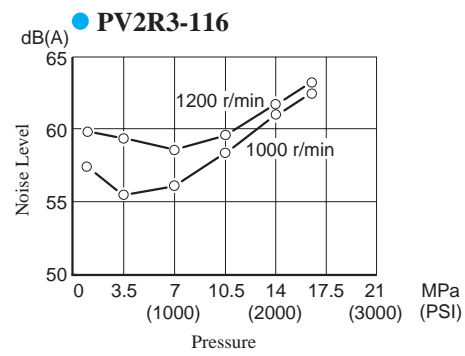
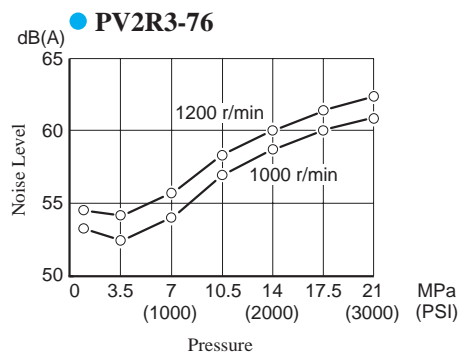
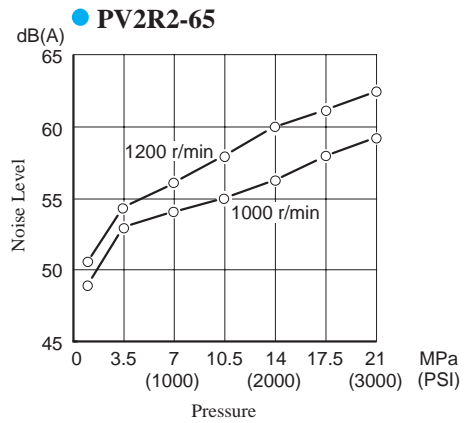
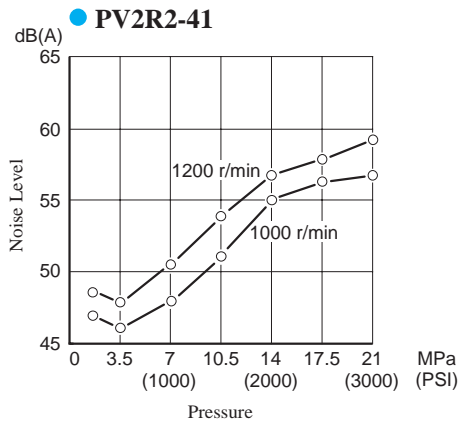
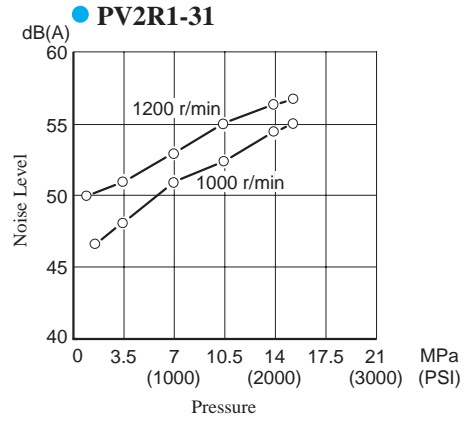
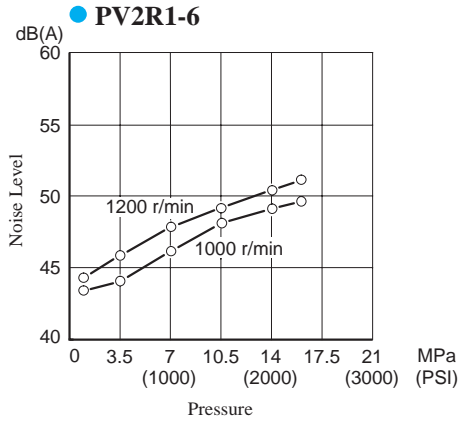

Typical Pump Characteristics at Viscosity 20 mm²/s (100 SSU) [ISO VG32 Oils, 50°C (122°F)]

● **PV2R1-6**

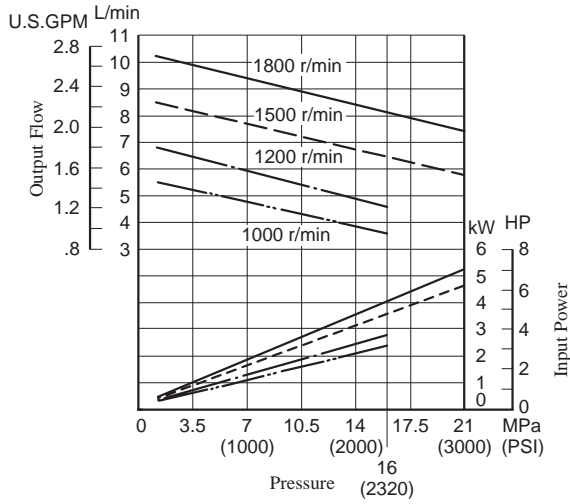

● **PV2R1-8**

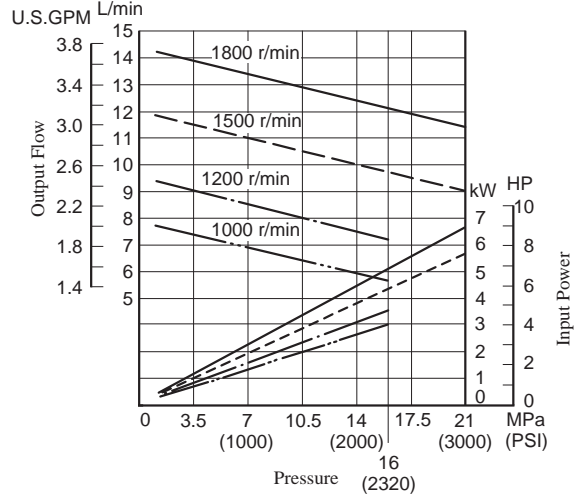

● **PV2R1-10**

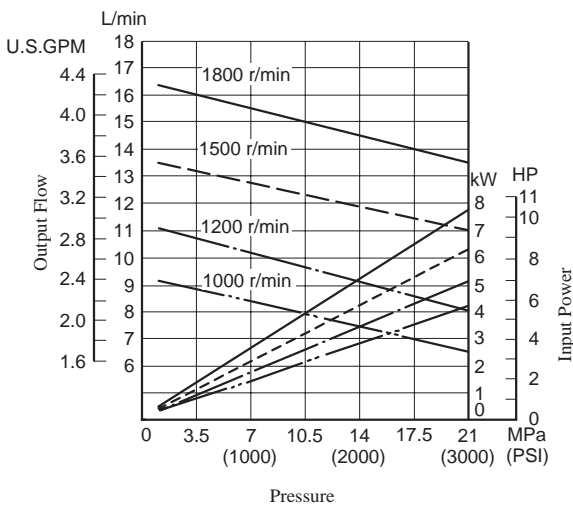

● **PV2R1-12**

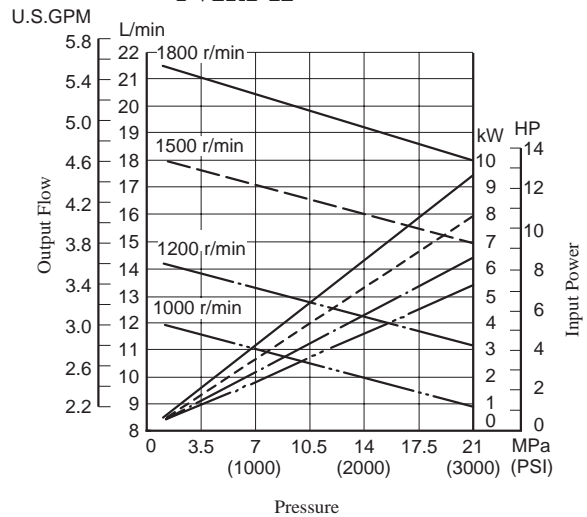

Typical Pump Characteristics at Viscosity 20 mm²/s (100 SSU) [ISO VG32 Oils, 50°C (122°F)]

B



"PV2R" Series
Single Vane Pumps

● PV2R1-14

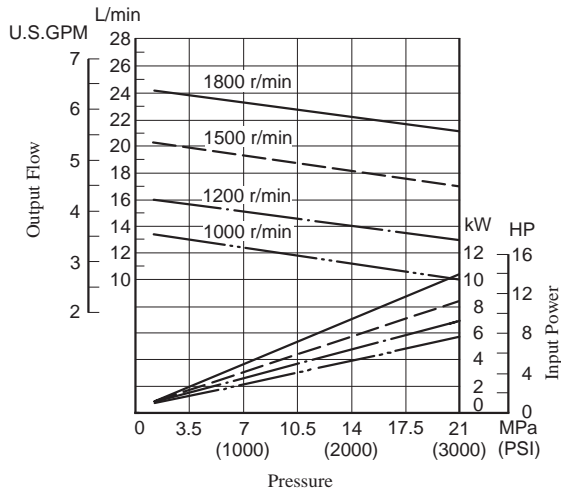

● PV2R1-17

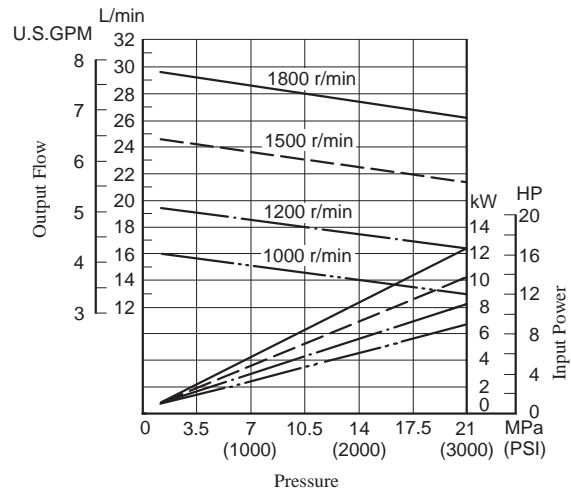

● PV2R1-19

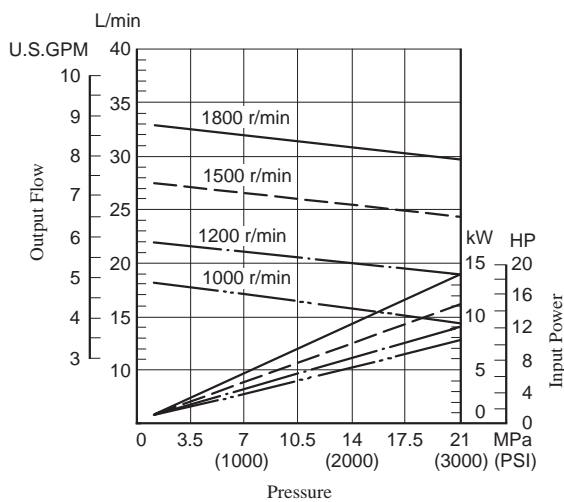

● PV2R1-23

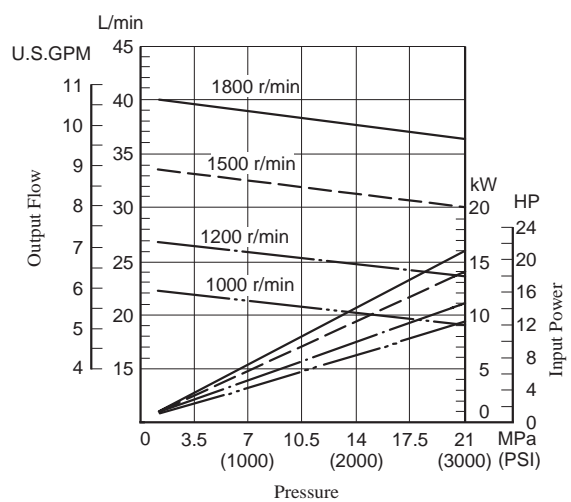

Typical Pump Characteristics at Viscosity 20 mm²/s (100 SSU) [ISO VG32 Oils, 50°C (122°F)]

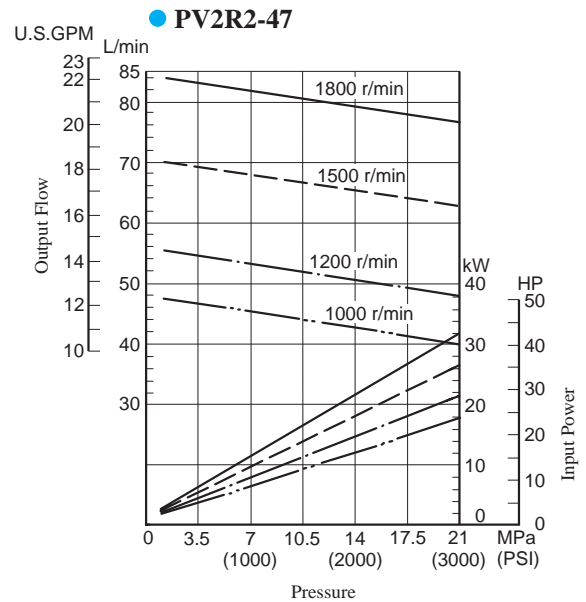
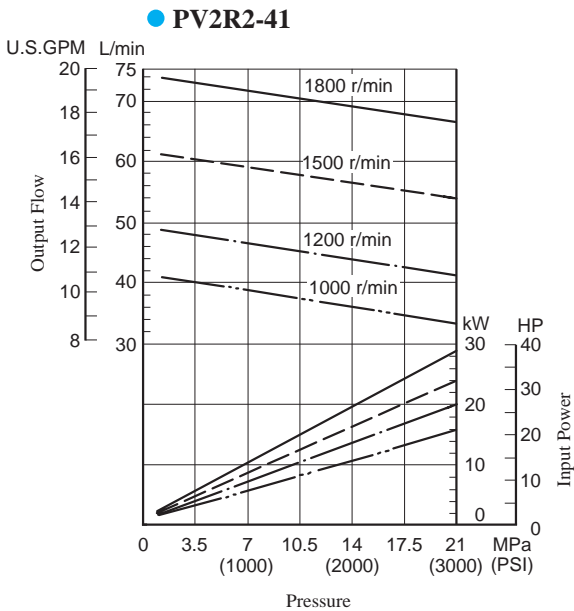
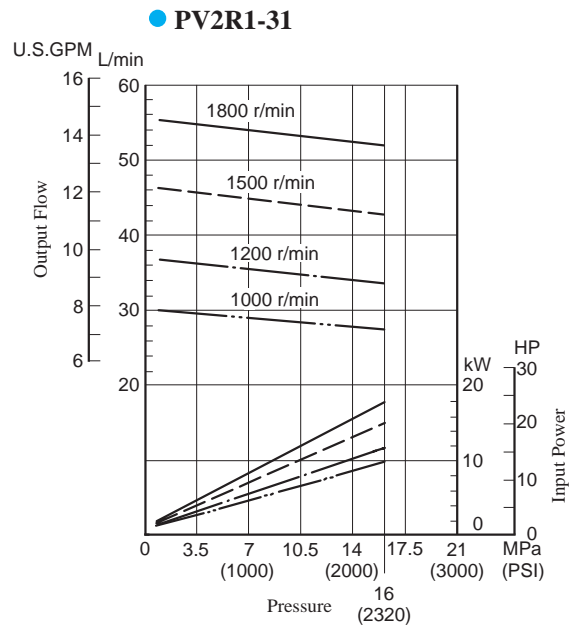
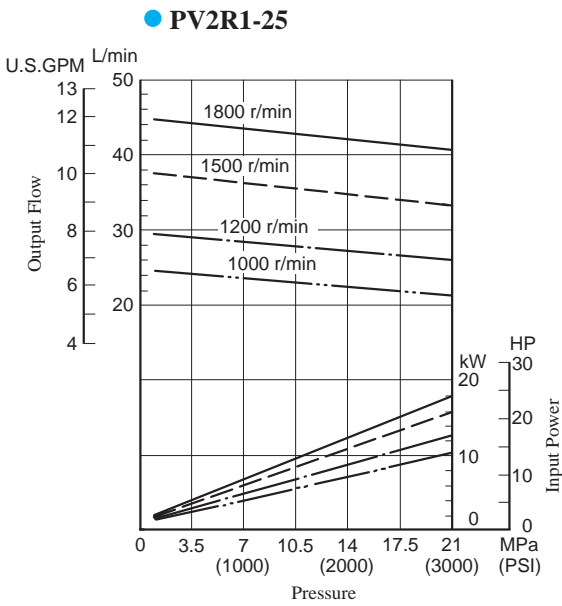

Typical Pump Characteristics at Viscosity 20 mm²/s (100 SSU) [ISO VG32 Oils, 50°C (122°F)]

B



"PV2R" Series
Single Vane Pumps

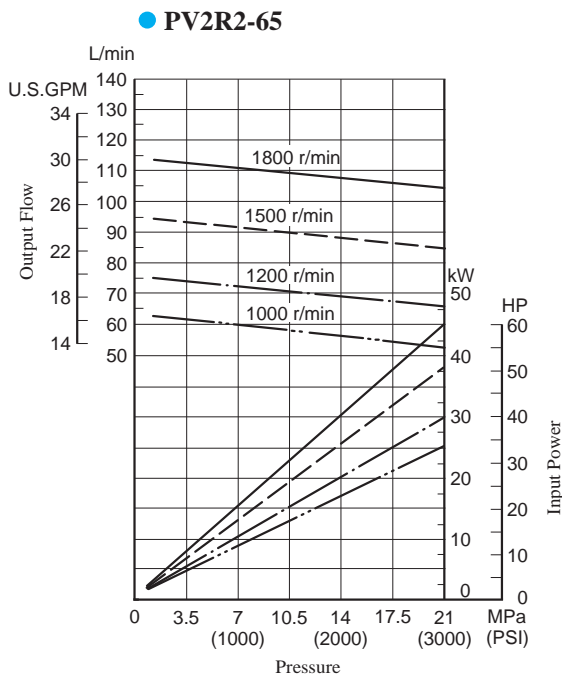
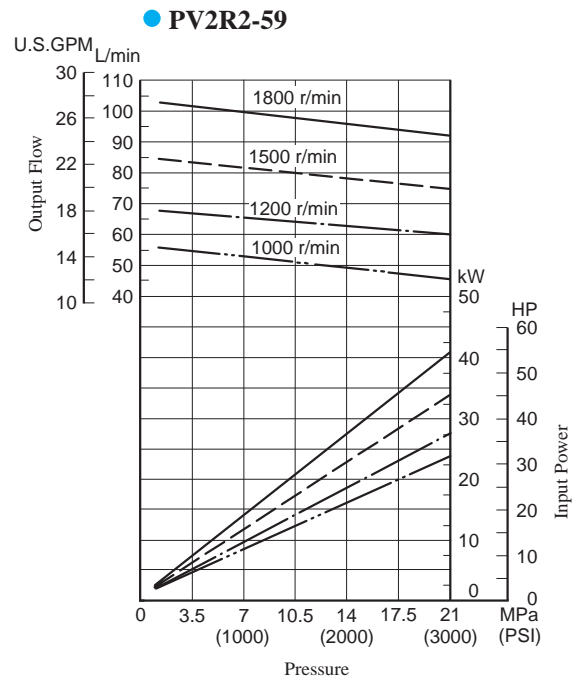
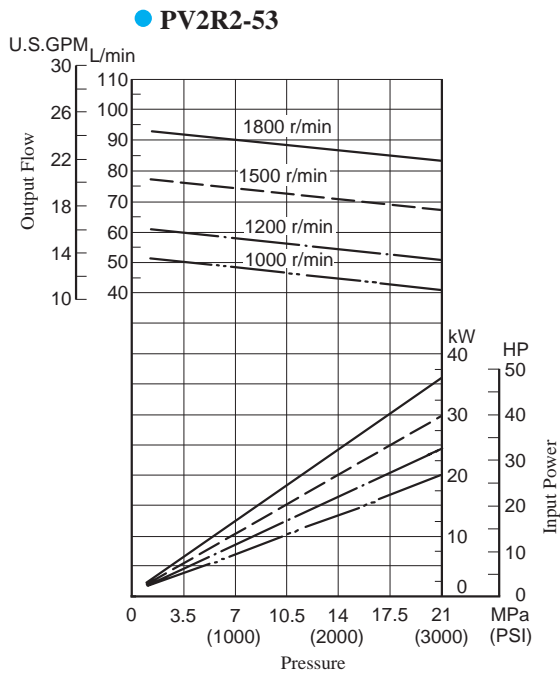

Typical Pump Characteristics at Viscosity 20 mm²/s (100 SSU) [ISO VG32 Oils, 50°C (122°F)]

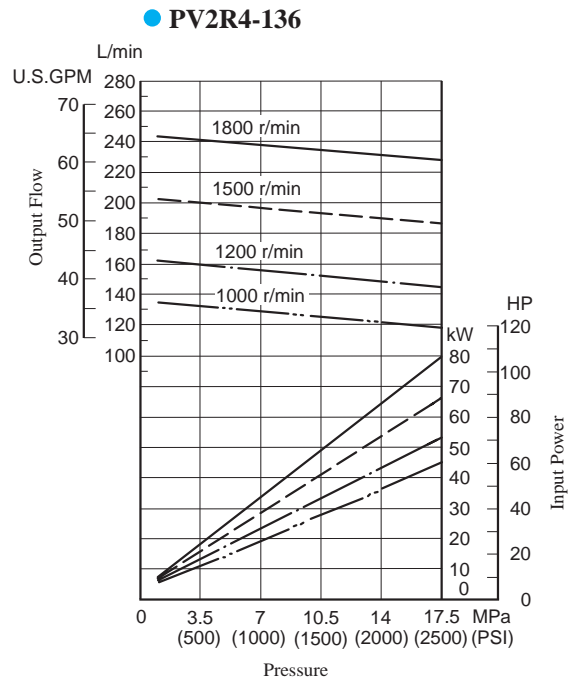
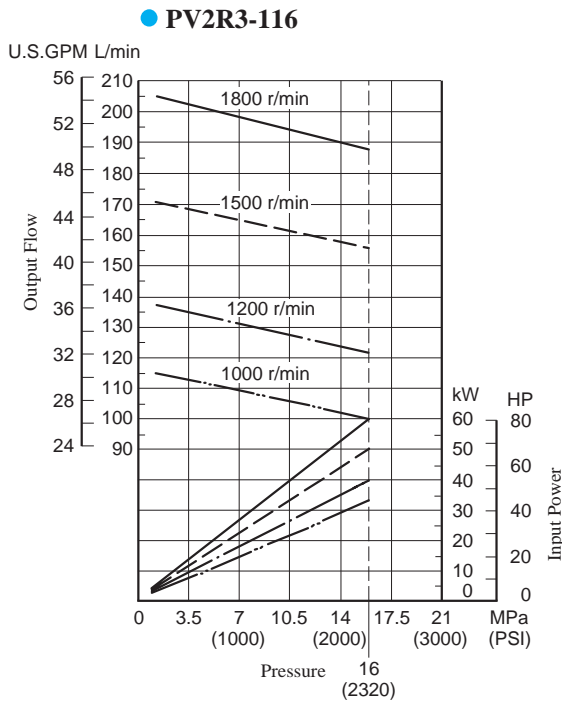
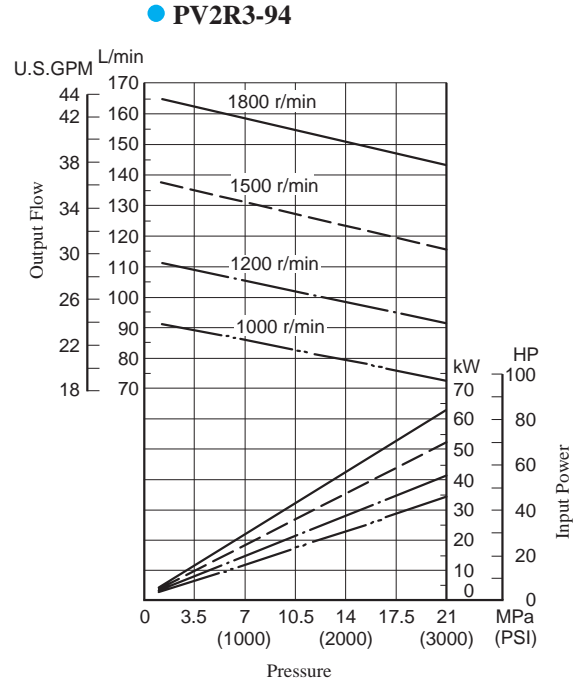
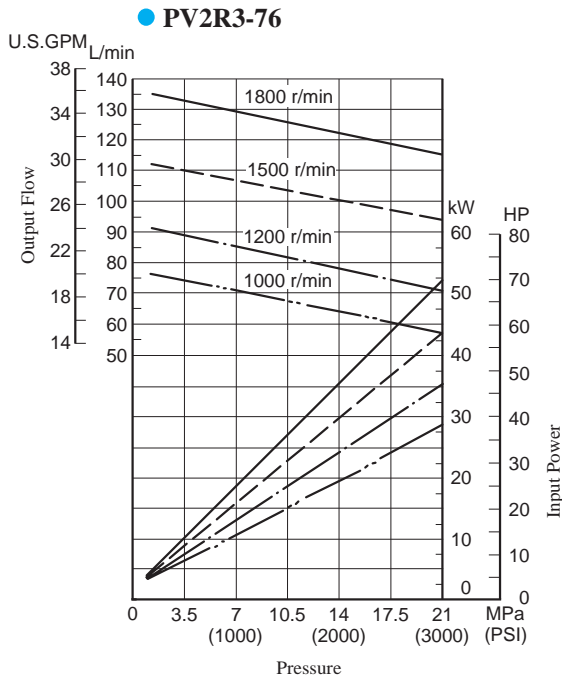

Typical Pump Characteristics at Viscosity 20 mm²/s (100 SSU) [ISO VG32 Oils, 50°C (122°F)]

B



"PV2R" Series
Single Vane Pumps

● **PV2R4-153**

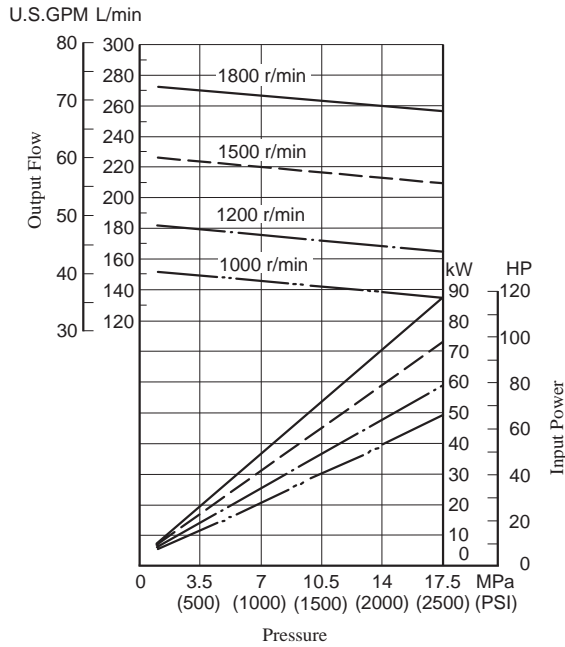

● **PV2R4-184**

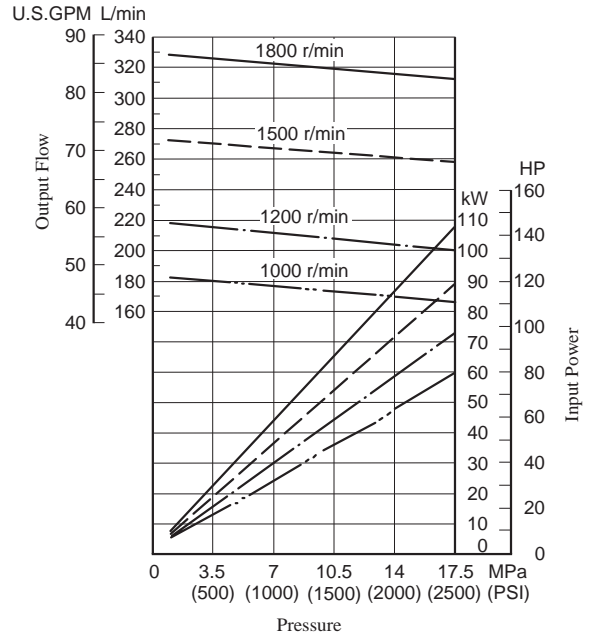

● **PV2R4-200**

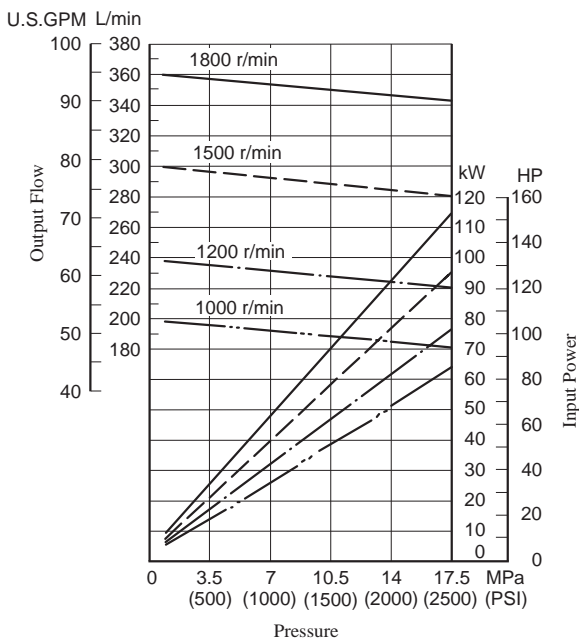

● **PV2R4-237**

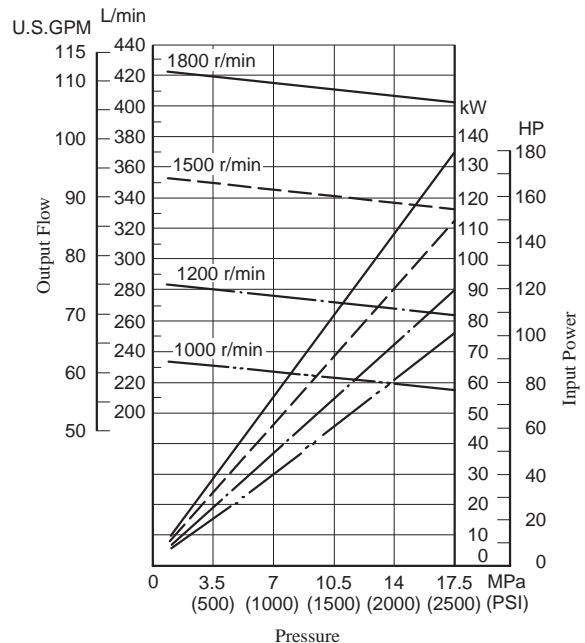

Spare Parts List

PV2R1-**-**-RAA-42/4290
 PV2R2-**-**-RAA-41/4190
 PV2R3-**-**-RAA-31/3190
 PV2R4-**-**-RAA-30/3090

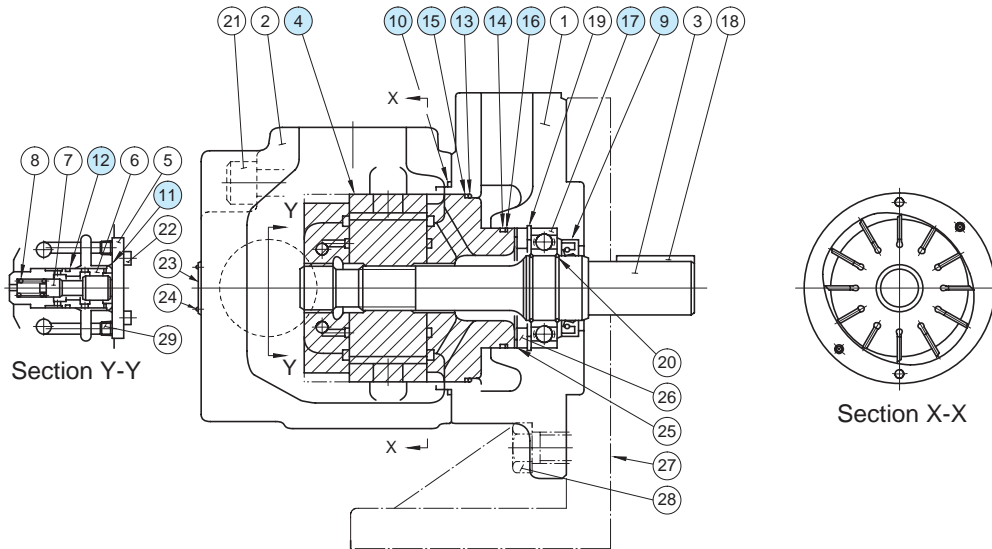

Cartridge Kits

Model Numbers	④ Cartridge Kit Numbers	Model Numbers	④ Cartridge Kit Numbers
PV2R1-6-**-RAA-42*	CPV2R1-6-R-42	PV2R2-41-**-RAA-41*	CPV2R2-41-R-41
PV2R1-8-**-RAA-42*	CPV2R1-8-R-42	PV2R2-47-**-RAA-41*	CPV2R2-47-R-41
PV2R1-10-**-RAA-42*	CPV2R1-10-R-42	PV2R2-53-**-RAA-41*	CPV2R2-53-R-41
PV2R1-12-**-RAA-42*	CPV2R1-12-R-42	PV2R2-59-**-RAA-41*	CPV2R2-59-R-41
PV2R1-14-**-RAA-42*	CPV2R1-14-R-42	PV2R2-65-**-RAA-41*	CPV2R2-65-R-41
PV2R1-17-**-RAA-42*	CPV2R1-17-R-42	PV2R3-76-**-RAA-31*	CPV2R3-76-R-31
PV2R1-19-**-RAA-42*	CPV2R1-19-R-42	PV2R3-94-**-RAA-31*	CPV2R3-94-R-31
PV2R1-23-**-RAA-42*	CPV2R1-23-R-42	PV2R3-116-**-RAA-31*	CPV2R3-116-R-31
PV2R1-25-**-RAA-42*	CPV2R1-25-R-42	PV2R4-136-**-RAA-30*	CPV2R4-136-R-30
PV2R1-31-**-RAA-42*	CPV2R1-31-R-42	PV2R4-153-**-RAA-30*	CPV2R4-153-R-30
		PV2R4-184-**-RAA-30*	CPV2R4-184-R-30
		PV2R4-200-**-RAA-30*	CPV2R4-200-R-30
		PV2R4-237-**-RAA-30*	CPV2R4-237-R-30

Seals & Bearings

Item	Name of Parts	Part Numbers				Qty.
		PV2R1	PV2R2	PV2R3	PV2R4	
9*	Oil Seal	ISD 26 42 8	ISD 30 42 8	ISD 35 55 11	ISD 45 68 12	1
10*	O-Ring	SO-NB-G80	SO-NB-G105	SO-NB-G135	SO-NB-G145	1
11*	O-Ring	—	—	—	SO-NB-P28	1
12*	O-Ring	—	—	—	SO-NB-P22A	1
13*	O-Ring	SO-NB-G60	SO-NB-G85	SO-NB-G115	SO-NA-G130	1
14*	O-Ring	SO-NB-G30	SO-NB-P46	SO-NB-A231	SO-NA-G80	1
15*	Back Up Ring	—	—	—	SO-BE-G130	1
16*	Back Up Ring	—	—	—	SO-BB-G80	1
17	Bearing	6004	6205	6207	6209	1

Note: 1) Item Nos. ⑬ and ⑭ (o-rings) and ⑮ and ⑯ (back up rings) are included in cartridge kit.
 2) For pumps for phosphate ester type hydraulic fluids different part Nos. are used. Please contact us.
 ★ When ordering seals, please specify the kit number from the table right.

List of Seal Kits

Pump Model Numbers	Seal Kit Numbers
PV2R1-**-**-RAA-42/4290	KS-PV2R1-40
PV2R2-**-**-RAA-41/4190	KS-PV2R2-40
PV2R3-**-**-RAA-31/3190	KS-PV2R3-30
PV2R4-**-**-RAA-30/3090	KS-PV2R4-30